



MODULYS GP

Unique, fully modular and redundant solution
Green Power 2.0 range from 25 to 600 kVA/kW

Three-phase UPS



The solution for

- > Computer rooms
- > Data centres
- > Banks
- > Healthcare facilities
- > Insurance
- > Telecom

Advantages

- > Ensures absolute business continuity
- > Aligns capacity to business demand
- > Optimises costs over the full life cycle

Certifications and attestations



Green Power 2.0 MODULYS GP is certified by TÜV SÜD with regard to product safety (EN 62040-1)

Green Power 2.0 MODULYS GP efficiency & performance are tested and verified by TÜV SÜD



SERMA TECHNOLOGIES

Green Power 2.0 MODULYS GP power module MTBF is calculated and verified higher than 1,000,000 hours by SERMA TECHNOLOGIES (IEC 62380)



With its flexible modularity providing seamless and risk-free power scalability up to 600 kW, the MODULYS GP range is the ideal solution for unscheduled site upgrades or incremental power evolutions. The installed power can be increased up to 600 kW by adding hot-swap plug-in power modules for incremental steps of 25 kW.

Designed with no single point of failure, the MODULYS GP offers all the advantages of the Green Power 2.0 technology.

Fully modular system

- Plug-in power module.
- Plug-in battery module.
- Plug-in bypass module.
- Top or bottom connection.
- Top-air exhaust module.

'Forever Young' concept

- Exclusive life cycle extension programme.
- Eliminates end-of-life criticality.
- Based on an electronics-free cabinet + a set of plug-in parts.
- Module compatibility guaranteed for 20+ years.
- Allows for the implementation of future module technology.

Totally redundant design

- N+1, N+x redundancy level.
- Designed for no single point of failure.
- No centralised parallel control.
- Totally independent power modules.
- Redundant parallel bus connection (ring configuration).

Enhanced serviceability performance

- Fast & safe maintenance based on hot-swap parts (power modules, bypass, electronic boards).
- Battery can be hot-swapped without shutting down the connected equipment.
- Ready for concurrent maintenance.

Advantages



Ready for Li-Ion battery

GREEN 117 A - GREEN 157 A

Standard electrical features

- Dual input mains.
- Internal maintenance bypass.
- Backfeed protection: detection circuit.
- EBS (Expert Battery System) for battery management.
- Battery temperature sensor.

Electrical options

- External battery cabinet.
- High capacity battery charger.
- ACS synchronisation system.
- Internal backfeed isolation device.

Standard communication features

- User-friendly multilingual interface with colour graphic display.
- Commissioning wizard.
- 2 slots for communication options.

Communication options

- Dry-contact, RS232/485 interfaces.
- MODBUS RTU.
- MODBUS TCP.
- BACnet/IP interface.
- NET VISION: professional WEB/SNMP interface for UPS monitoring and shutdown management of several operating systems.

Remote monitoring service

- LINK-UPS, remote monitoring service that connects your UPS to your Critical Power specialist 24/7.

Technical data

MODULYS GP UPS SYSTEM			
	25 to 200 kVA	25 to 400 kVA	25 to 600 kVA
Power (Sn)	25 to 200 kVA	25 to 400 kVA	25 to 600 kVA
Power (Pn)	25 to 200 kW	25 to 400 kW	25 to 600 kW
Number of power modules	1 to 8	1 to 16	1 to 24
Input / output	3/3		
Redundant configuration	N+x		
INPUT			
Voltage	400 V 3ph+N (340 V to 480 V)		
Frequency	50/60 Hz ±10%		
Power factor / THDI	> 0.99 / < 3%		
OUTPUT			
Power factor	1 (according to IEC/EN 62040-3)		
Voltage	380/400/415 V ±1% 3ph+N		
Frequency	50/60 Hz ±0.1%		
Voltage distortion	< 1% (linear load), < 4% (non-linear load according to IEC 62040-3)		
Short-circuit current	up to 3 x In		
Overload	125% for 10 minutes, 150% for 1 minute		
Crest factor	3:1		
BYPASS			
Voltage	rated output voltage ±15% (configurable with from 10% to 20%)		
Frequency	50/60 Hz ±2% (configurable for GenSet compatibility)		
EFFICIENCY (TÜV SÜD VERIFIED)			
Online double conversion mode	up to 96.5%		
ENVIRONMENT			
Ambient temperature	0 °C to 40 °C (15 to 25 °C for maximum battery life)		
Relative humidity	0 to 95% without condensation		
Maximum altitude	1000 m without derating (3000 m max)		
Acoustic level at 1 m	< 55 dBA		
SYSTEM CABINET			
Width	600 mm	2 x 600 mm (combinable system) 2010 mm (fully integrated solution)	3 x 600 mm (combinable system) 2610 mm (fully integrated solution)
Depth	890 mm		
Height	1975 mm		
Weight (empty cabinet)	210 kg	2 x 210 kg (combinable system) 780 kg (fully integrated solution)	3 x 210 kg (combinable system) 1010 kg (fully integrated solution)
Degree of protection	IP20		
STANDARDS			
Safety	IEC/EN 62040-1, AS 62040.1.1, AS 62040.1.2		
EMC	IEC/EN 62040-2 Class C2, AS 62040.2		
Performance	IEC/EN 62040-3, AS 62040.3		
Seismic compliance	On request according to Uniform Building Code UBC-1997 Zone 4		
Environmental	IEC/EN 62040-4		
Product declaration	CE, RCM (E2376)		
POWER MODULE			
Height	3U		
Weight	34 kg		
Type	Hot plug-in / Hot-swappable		
MTBF	> 1 000 000 hours (calculated and verified)		

Best practice award



Frost & Sullivan has awarded SOCOMEC with its prize for Innovation & Excellence in Developing Scalable, Best-in-Class Products and Solutions.

SOCOMEC's vast expertise and technological know-how in modular UPS solutions have enabled it to develop a new modular, three-phase UPS that employs the latest cutting-edge technology combined in a unique design and architecture.

MODULYS GP

Three-phase UPS

Green Power 2.0 range from 25 to 600 kVA/kW

The benefit of a fully modular system

Easy to manage

- Totally modular system for power scaling or for quickly adapting to business changes.
- Standardised system and modules covering a wide range of power and back-up times.
- Repeatable and standardised scalable architecture for time-saving design for different configuration & architecture requirements.

Pay as you need

- No prior expenditure for unpredictable future extensions in power and back-up time.
- Space saving thanks to reduced footprint and front access.
- Eliminates installation rework costs when new capacity is required from IT physical infrastructure.
- No risk of design oversizing due to project data uncertainty.

Everything front-access

- Connections, switches, manual bypass, static bypass, power modules and all the electric parts have front-access.
- Total footprint is not increased as rear extra clearance for maintenance is not needed.
- Easy, quick, comfortable, safe and risk-free installation and maintenance.
- More reliable system.

The benefit of a totally redundant design

Total resilience

- Electronics-free (failure-free) cabinet.
- Totally independent and self-sufficient modules.
- Real module selective disconnection with galvanic separation.
- No centralised control for parallel and load sharing management.
- Totally segregated, fully sized and centralised bypass.
- Configurable N+1 to N+x redundancy (power & battery).
- No single point of failure.
- Redundant parallel bus connection (ring configuration).

Optimum reliability

- Power module designed for superior robustness proved by an independent body (MTBF > 1,000,000 hr).
- Highly robust bypass (MTBF > 10,000,000 hr).
- Acid leak-proof modular battery box.

Maximum availability

- Fast recovery of lost redundancy thanks to minimum MTTR (Mean Time To Repair).
- No risk of downtime during power upgrading and maintenance.
- No risk of failure propagation.

Cost-effective redundancy

- No need to duplicate the system hardware to get redundancy.
- Redundancy achievable simply by adding one more power and battery module.
- Redundancy can be easily combined with power scalability.

A flexible modular UPS system

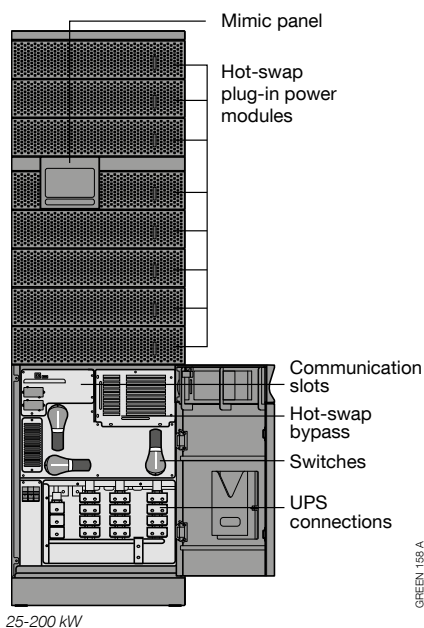

Fully integrated solution

- UPS system cabinets + coupling cabinet + base plates.
- It allows a complete, simple and very reliable installation, with unique IN/OUT and fully sized manual bypass.
- Innovative base plates simplify the installation and allow a tidy and segregated cabling for higher system reliability.

Combinable system

- It allows the creation of a system when:
 - an external coupling cabinet is already present (i.e. in case of replacement of an existing UPS),
 - a coupling cabinet with a special configuration is required and it has to be developed specifically,
 - the UPS system cabinets cannot be installed side-by-side.

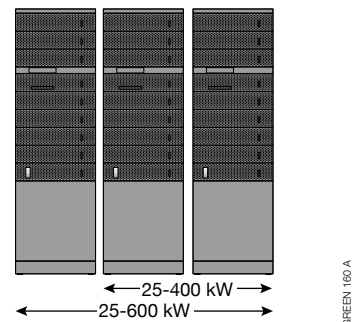
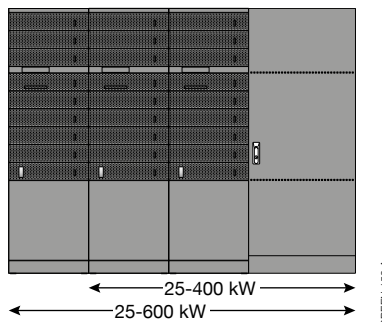

Fully integrated solution: easy and safe installation

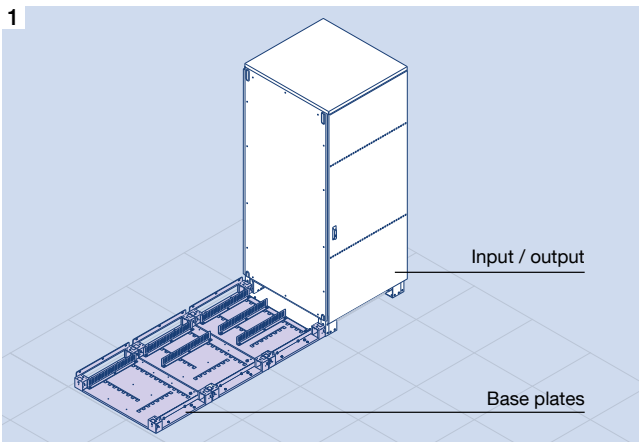

Innovative base plates simplify the installation.

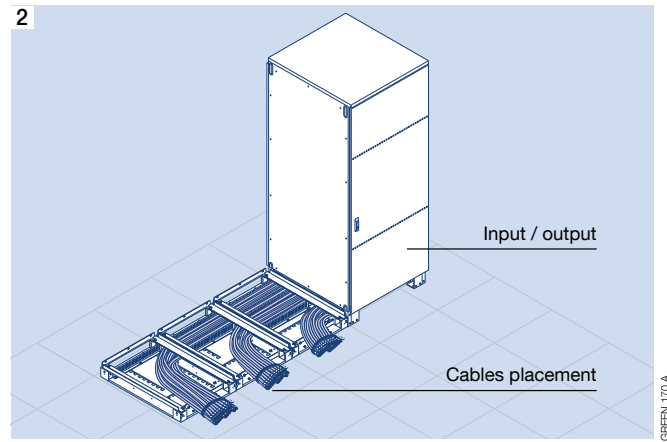

Safe, reliable and time-saving cabling management.

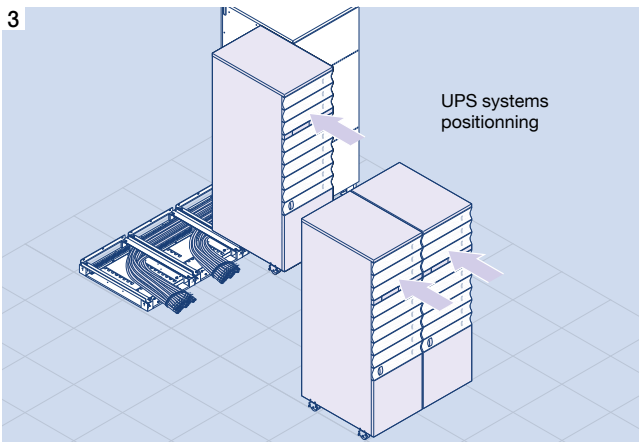

Cabinets are easy to move (no pallet truck required), position and assemble.

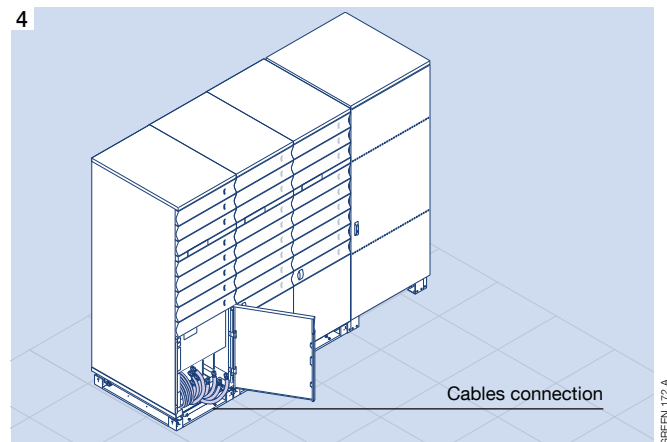

Easy cabling for a tidy and reliable solution.

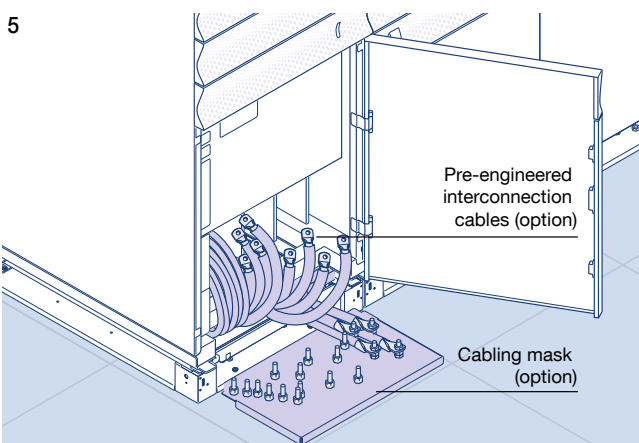

Simplified cable positioning and risk-free connections.

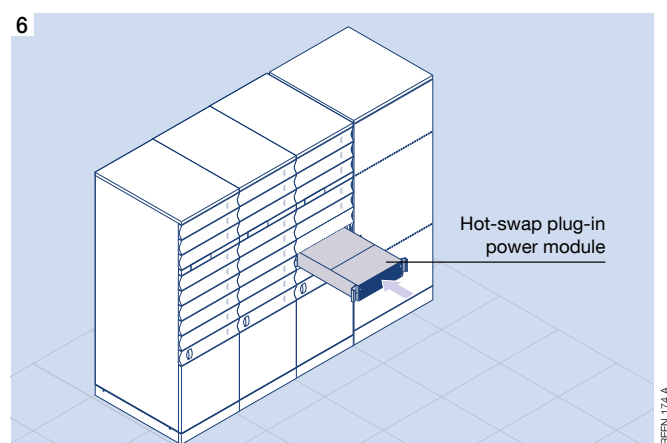

Automatic self-configuring hot-swap plug-in power modules.

MODULYS GP

Three-phase UPS

Green Power 2.0 range from 25 to 600 kVA/kW

Seamless and risk-free scalability & upgrading

- MODULYS GP protects critical loads in all conditions, including power upgrading and maintenance procedures.
- No risk of human error and downtime.

On-line power scalability

- MODULYS GP allows you to increase power scalability and redundancy while keeping the load protected on inverter mode simply by plugging-in a new power module and waiting for its automatic self-configuration, without any human intervention.

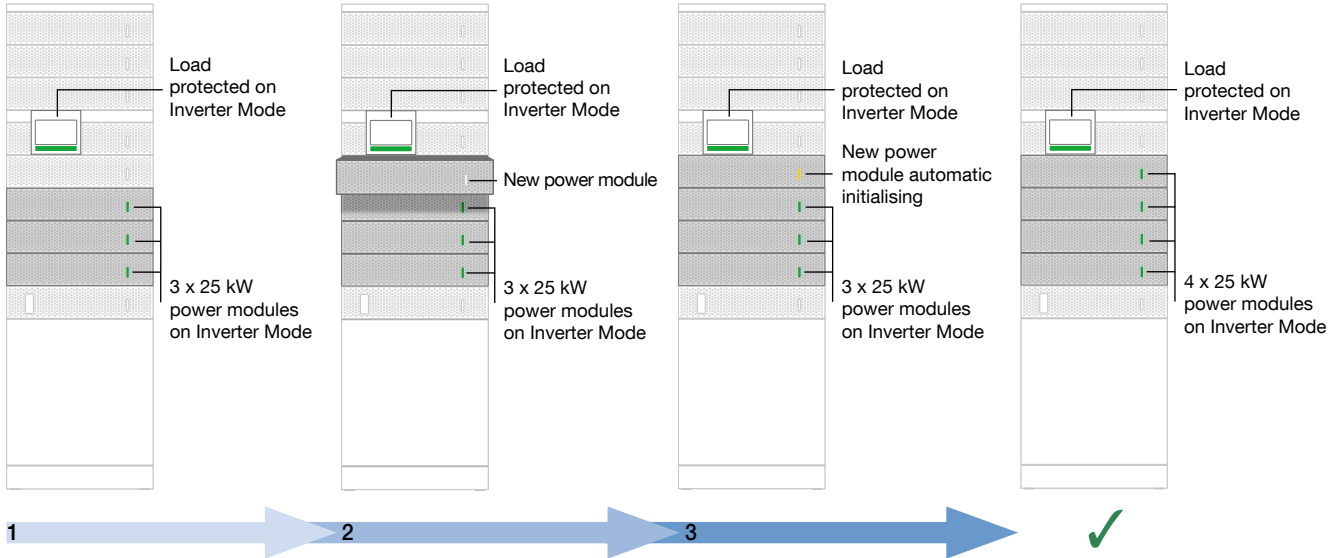

Power module automatic firmware alignment

- Even the power module firmware alignment is totally risk free.
- When a new power module is plugged in, the system checks what firmware version is embedded and if it is different automatically aligns it to one of the other modules. The load is protected at all times while running on inverter mode.

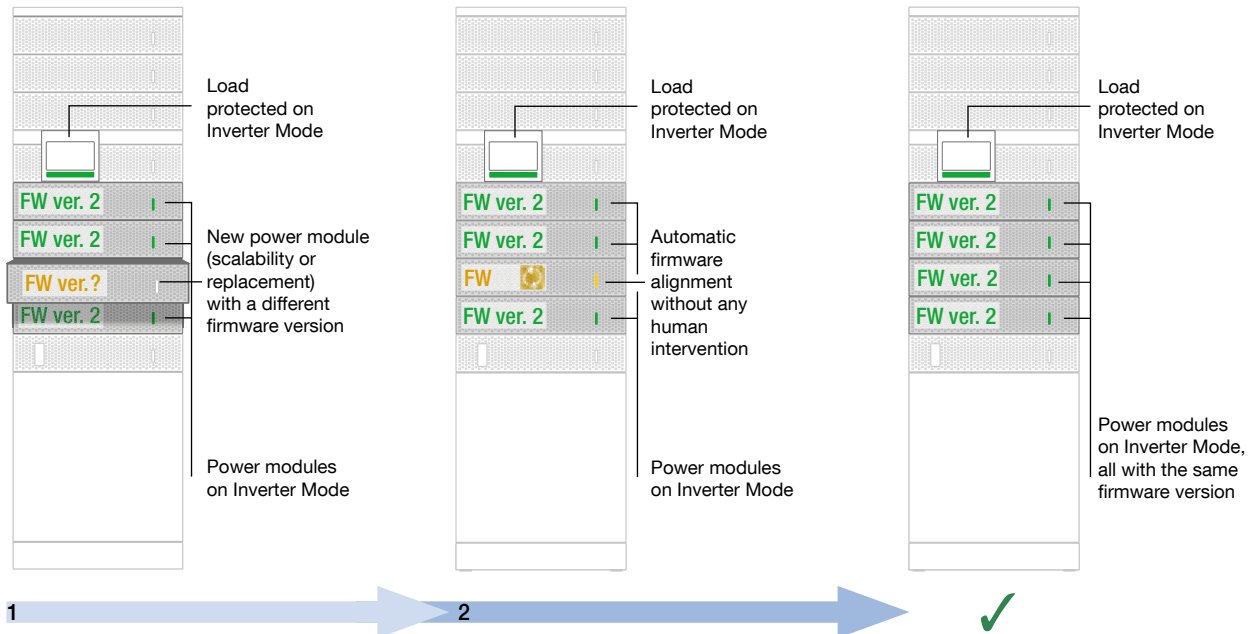

On-line global firmware update

- It is also possible to upgrade the global firmware without switching to bypass to keep the load protected on Inverter mode.
- Automatic procedure for a risk-free firmware upgrade.

Flexible and modular back-up times

MODULYS GP offers modular solutions to meet all your requirements for back-up times (whether a few minutes or several hours) without compromising flexibility and scalability.

Internal hot swap battery

- Designed for short back-up time.
- Long-Life batteries available as standard.
- Compact solution with a small footprint.

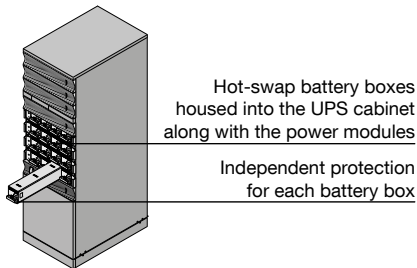

Modular hot-swap battery cabinets

- Designed for medium and long back-up times.
- Long-Life batteries available as standard.
- Vertical and horizontal modularity ensuring flexible back-up times.

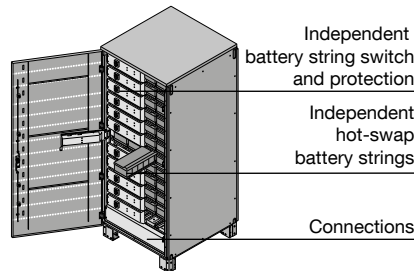

Modular battery cabinet

- Designed for long back-up times.
- Long-Life batteries available as standard.
- Horizontal modularity ensuring flexible back-up times.

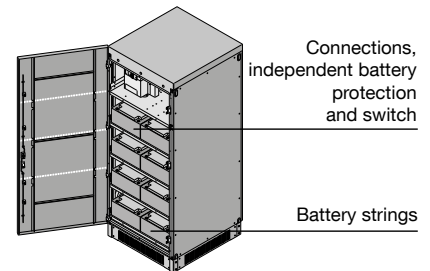

MODULYS GP "Forever Young" concept

- MODULYS GP excels not only in efficiency, flexibility, capacity management and sustainability - five aspects that are crucial for optimum performance.
- It employs an exclusive concept called 'Forever Young' which allows the life-cycle extension of MODULYS GP and eliminates the criticality of system end-of-life.
- It also keeps the system open for the implementation of future technology improvements without modifying the infrastructure.

The 'Forever Young' concept:

- Is based on electronics-free (failure-free) cabinets where the components that are subject to ageing are all plug-in and therefore quick and easy to replace.
- Allows life-cycle extension via periodic replacement of power modules before they start ageing.
- Provides an always up-to-date system that uses the latest technology.
- Assures power modules and spare part compatibility and availability for more than 20 years.

